

Decontamination Poultry House Sprayer

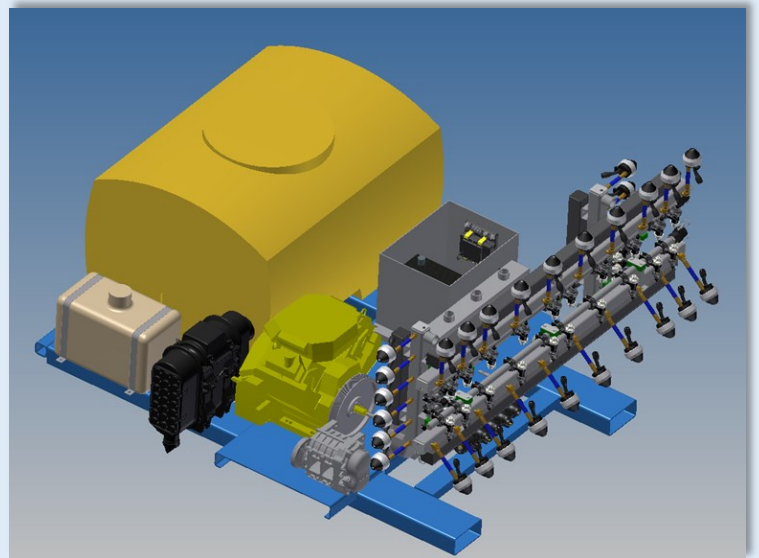

Made in the USA

- Effective for decontamination of poultry houses after each flock
- Simultaneously sprays in all four directions
- Mounts easily on small truck or pickup; fully self contained
- Applies approximately 3 ounces per 100 square feet of floor space
- 36 electrostatic spray nozzles
- Efficient and effective ultra-low volume sprayer
- 40 micron droplet size
- 100 gallon (378.541 l) tank for chemical/antimicrobials
- Includes: electronic controls, air blower, and liquid pump, etc
- Gasoline motor (diesel and propane optional)

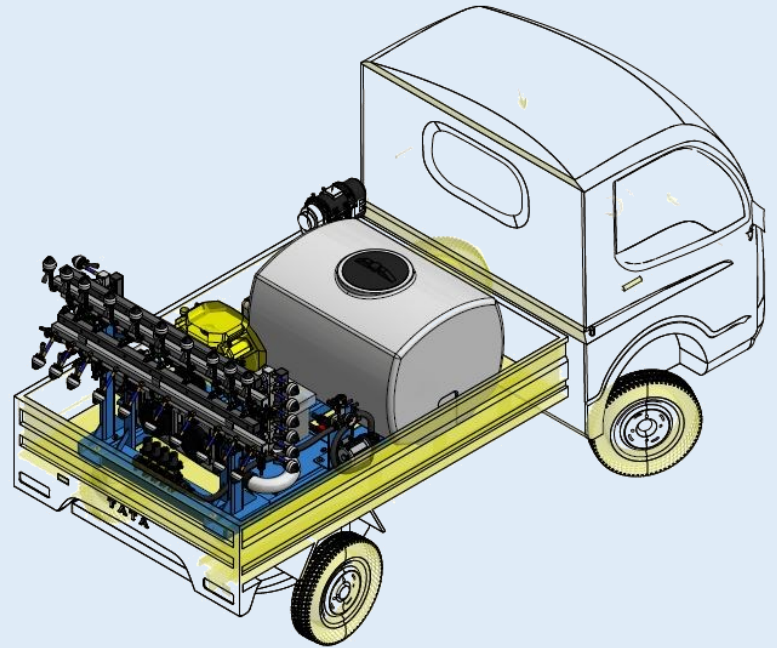

62 Morrison St. Watkinsville GA 30677

706-769-0025 • 1-800-213-0518

info@maxcharge.com

www.maxcharge.com

